

Rustrak Recorder

Instruction Manual

Models: 288, 388, 4388, 7288, 291, 391, 4391

Features: 217, 217N, 205, 137, 437, 2146, 3146, 4146



ISE, Inc.

10100 Royalton Rd.
Cleveland, OH 44133 USA

Tel: (440) 237-3200 • Fax: (440) 237-1744

<http://instserv.com>

INTRODUCTION

This manual describes standard RUSTRAK Series 200, 300, 4000, 7000 and optional features with which they may be equipped. All recorders described are for measuring DC voltage or current.

If the recorder is a Series 300, 4000, or 7000 and one or more of the channels is not a DC channel, separate manuals are included to describe those channels.

OTHER RUSTRAK MANUALS, INSTRUCTION AND DATA SHEETS

Following is a partial listing of other manuals and information which are available.

DESCRIPTION	MODEL OR FEATURE
Temperature, Pressure	2122, 2133, 2144, 2155, 2155A, 2155AN, 2162
AC Voltage & Current	288R, 293, 2118, 2107, 2113, 230, 2186
Adapt-a-Socket	236A, 236B
Event	292-4, 292-8, 392-16, 4392-24, 921
Refrigeration	238
Servo and Plug In	400A, P4000
Humidity, Temperature	225
Cathodic Protection	189
Dissolved Oxygen, Temp.	192
Power	264
Rack Mounting	2176, 3176
Escutcheon	2196
Flush Mounting	9A, 9B
Mounting Template	200 Series
Mounting Template	300 Series
Extended View	2156
Weatherproof Enclosure	197
Chart Viewer	186, 3186

TABLE OF CONTENTS

	PAGE
Introduction	2
Rustrak Manuals	2
Recorder Description	3
Specifications, 288, 291, 2146, 300	3
Specifications, 4000, 7000, 217, 21 7N, 205	4
External Wiring & Installation	5
Safety Considerations	5
Calibration, 200, 300, 4000, 7000, 217, 2194	6
Chart Loading, Reroll	7
Chart Loading, Tearoff	8
Standard Features, 200, 300, 4000, 7000	9
Scale Replacement, 200, 300, 4000	9
Two Point Feature (F137)	10
Four Point Feature (F437)	10
Controller Operation, 205	11
Troubleshooting	12
Replaceable Parts, 200, 300, 4000	13
Applications Assistance	14
Service & Repair	14
Special Features	14
Chart Paper	14

RECORDER GENERAL DESCRIPTION

The RUSTRAK galvanometric recorder consists of several basic elements; galvanometer, spring loaded striker, backup bar (writing edge), chart drive motor and cam, and pressure sensitive paper.

A rotating cam lifts the striker away from the galvanometer pointer allowing free movement of the pointer. The cam allows the striker to fall against the pointer pressing it against the pressure sensitive paper. The force is absorbed by the backup bar located behind the paper. This action removes the white top coating on the paper and exposes the black base material at the point where the pointer and backup bar cross. Each strike makes one dot.

When chart speed, and cam RPM are chosen properly, the succession of dots has the appearance of a continuous line.

The motor which rotates the cam also provides the motion to move the chart paper through the recorder.

MODEL 288 RECORDER SPECIFICATIONS

Single channel analog chart recorder for measuring DC voltage and DC current. Use of different galvanometers and multipliers produces voltage sensitivity from 10 mV to 500 V and current sensitivity from 10 μ A to 1 mA and higher using shunts.

Accuracy	\pm 2% (current recorder w/o shunt)
Response Time	1 second maximum
Usable Chart Width	2 5/16"
Chart Length	63 feet
Chart Speed	1/48"/hr to 480"/hr with std. motors and gear trains
Chart Motor Voltage	115 or 230 V, 50 or 60 Hz 6, 12, 24, 48 VDC unregulated or inverter motors
Striking Rate	1 per 12 sec. to 4 per sec.
Dimensions	3 5/8"W x 5 5/8"H x 4 5/16"D

MODEL 291 RECORDER

Weight	3 3/4 pounds
--------	--------------

SPECIFICATIONS

Two analog channels in a Model 288 case and chart drive configuration Use of different galvanometers and multipliers gives voltage sensitivity from 57 mV to 500 V and current sensitivity from 10 μ A to 1 mA and higher using shunts.
Usable Chart Width Two one inch analog channels

Refer to Model 288 specifications at left for all other specifications.

MODEL 2146 RECORDER SPECIFICATIONS

One analog channel and one event channel in a Model 288 case and chart drive configuration. Use of different galvanometers and multipliers gives voltage sensitivity from 57 mV to 500 V and current sensitivity from 10 μ A to 1 mA and higher using shunts.

Usable Analog Chart Width	two inches
Event Channel	one 5/16 inch
Event Indication	1/16 inch rectangular trace with on-off signal
Event Response Time	10 Events per second
Event Voltage	6, 12, 24, 48 VDC and 6, 12, 24, 48, 115, 230 V 50/60 Hz +20 —15%
Event Power	2 Watts Nominal

SERIES 300 RECORDER SPECIFICATIONS

The Series 300 is a dual width recorder in which Models 288, 291, 2146, four or eight events or other combinations are available.

Dimensions	6 5/8"W x 5 5/8"H x 8 1/4"D
Weight	6 pounds

SERIES 4000 RECORDER SPECIFICATIONS

The Series 4000 is a triple width recorder in which Models 288, 291, 2146, four to sixteen events or other combinations are available.

All 4000 Series recorders have two speed chart motors (2 and 8 RPM) which are push button controlled from the right hand panel.

Dimensions 11"Wx5 5/8"Hx8 1/4"D
Weight 8 pounds

SERIES 7000 RECORDER SPECIFICATIONS

Single 100mm wide analog channel with up to three events in a Series 300 case and chart drive configuration. Basic sensitivity is 5mA at 140 ohms. Other voltage and current sensitivities are obtained with amplifiers, multipliers, or shunts.

Accuracy $\pm 2\%$ (current recorder w/o shunt)
Response Time 1 second maximum
Analog Chart Width 100mm
Event Channels Up to three 5/16" spacing
Event Indication 1/16 inch rectangular trace
Event Response Time 10 Events per second
Event Voltage 6, 12, 24, 48 VDC and 6, 12, 24, 48, 115, 230 V 50/60 Hz +20 —15%
Event Power 2 Watts Nominal
Chart Length 63 feet
Chart Speed 1/48"/hr to 480"/hr using all std. motors and gear trains
Chart Motor Voltage 115 or 230 V. 50 or 60 Hz
6, 12, 24, 48 VDC unregulated or inverter motors.

Dimensions 6 5/8"W x 5 5/8"H x 8 1/4"D
Weight 6 pounds
Striking Rate 1 per 12 sec. to 4 per sec.

AMPLIFIER FEATURE 217 SPECIFICATION

DC preamplifiers may be added to the basic Models 288,291,2146 as well as any analog channel in a Series 300,4000 or 7000. Standard spans are from 10 mV to 100 mV with input resistance of 50,000 ohm

Accuracy $\pm 2\%$ (voltage or current)
Ambient Temperature 0 to 50C
Recorder Dimensions Series 300, 4000 see recorder specifications

Series 200
35/8"Wx 55/8"Hx 6"D
Span Any Span Between 10 & 100 mV
Offset & Suppression Up to $\pm 1 \times$ Span
Model 2194 is a fixed gain version of the 217 Feature with 10,000 ohm input resistance, and a span of 10 mV (1 uA)

AMPLIFIER FEATURE 217N SPECIFICATION

Specifications for 217 apply except

Span Any Span between 1 and 9.9 mV
Offset & Suppression Up to $\pm 5 \times$ Span

CONTROLLER FEATURE 205 SPECIFICATION

Controller feature may be added to any analog channel of Series 200,300, 4000 or 7000. The maximum number of setpoints is two per channel.

Type of Output 2 Amp Relay
Number of Setpoints one or two
Type of Setpoint High (A) or Low (B)
Input Sensitivity Same as recorder sensitivity
Dead Band .2% to 5% adjustable
Indication Red LED indicates when relay energizes

EXTERNAL WIRING, SERIES 200

All recorders have a label inside showing all terminal and pin numbers regardless of whether or not they have been supplied pre-wired. The serial plate gives all voltage, frequency, model and serial information for the particular recorder.

The table below shows standard connection for Series 200 AC powered recorders.

CONNECTOR PIN #	MODEL 288	MODEL 291	MODEL 2146
1	+ galvo	+ galvo LH	+ galvo
2	- galvo	- galvo LH	- galvo
3	high line	high line	high line
4	low line	low line	low line
5	case	+ galvo RH	event
6	NC	- galvo RH	event
lug	not used	case	case

When the above models are supplied with attached line cord, pins 3 and 4 are not used. (Includes CSA approved models)

When the above models are supplied with DC motor, pin 3 is positive and pin 4 is negative.

When a 217 feature is installed, the recorder has attached line cord, and the signal input is to the red (positive) and black (negative) binding posts.

EXTERNAL WIRING, SERIES 300, 4000, 7000

These models are supplied with attached line cord as standard. All other inputs and outputs are via rear barrier strip or binding posts. The inside label identifies all connections.

EXTERNAL WIRING, SPECIAL

When the recorder deviates from the standard wiring or operation the special feature is noted on the cover of this manual and details listed on page 14. Applicable drawings, specification sheets etc. are attached.

INSTALLATION, SERIES 200, FEATURES 217, 217N, 205

These recorders are furnished with A-6464 hardware kit for bench or panel mounting. Instructions are in the kit. A template for panel cutout dimensions is available.

INSTALLATION, SERIES 300, 4300

These recorders are shipped with all hardware installed as a bench mount. A modification kit is available for panel mounting.

SAFETY CONSIDERATIONS

All Rustrak recorders provide some method for grounding the metal case. Use this provision. Do not assume that the recorder is grounded because it is plugged into a 3 prong outlet. Make certain your power system ground is not faulty. *FAILURE TO PROPERLY GROUND AN ELECTRICAL DEVICE CAN BE FATAL* This applies to battery operated recorders as well because the signal itself could be a lethal voltage.

Recorders using sensitive signal conditioners may not operate properly without a case ground.

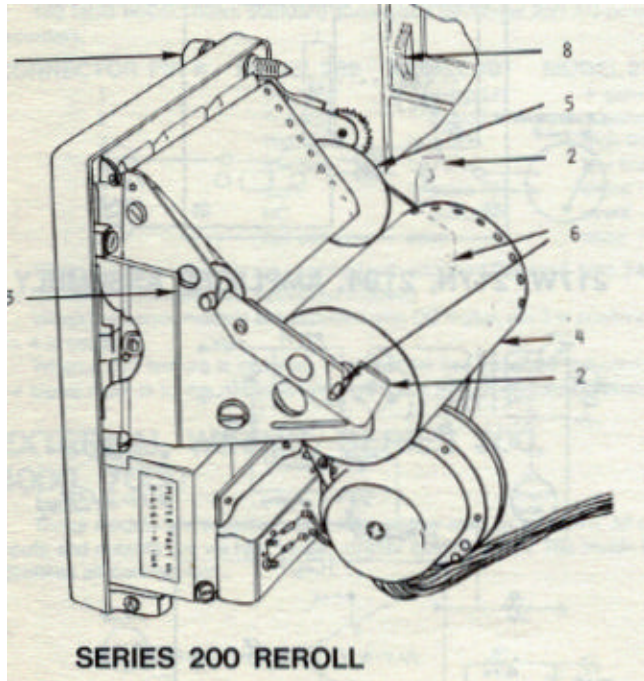

CHART LOADING, RE-ROLL MODE

A warning to "RENEW CHART" appears on the last three feet of each roll of paper. Do not use partial rolls of paper in re-roll mode. Refer to diagram at left.

- 1) Turn power off before loading chart paper.
- 2) Open recorder by loosening thumbscrew (1).
- 3) Unlatch paper retaining clips (2).
- 4) Open panel to chassis latch (3) RH side plate.
- 5) Remove supply (4) and take up roller (5). If paper is still attached to supply roller, carefully slide the paper from between the front panel and chart drive. Do not pull the paper backwards through the recorder because of the danger of snagging the pointer.
- 6) Insert the supply roller into the new roll of chart paper. The perforated end of the paper is nearest to the roller shoulder.
- 7) Unroll about a foot of paper. Slide the paper between the panel and side plate, sprocket holes first. Keep paper taut and close to the drive drum to prevent snagging the pointer.
- 8) Engage the supply roller shaft in both seating notches (6) and check to be sure that the paper sprocket holes engage the time drum sprockets.
- 9) Slide cardboard sleeve all the way on the take up roller against the disc.
- 10) Butt paper against disc and tape the paper to the sleeve, printed side out. Wrap a few turns of the paper to be sure paper is started true.
- 11) Continue rolling paper and place roller shaft into notches. (Lower notch LH side).
- 12) Close clips (2), latch (3) and recorder front panel. Tighten thumbscrew(1).
- 13) Advance paper with the chart advance wheel (8), to assure that paper moves through the recorder. Set to time

CHART LOADING, TEAR-OFF MODE

A warning to "RENEW CHART" appears on the last three feet of each roll of paper. Refer to the diagram at right.

- 1) Turn power off before loading chart paper.
- 2) Open recorder by loosening thumbscrew (1).
- 3) Unlatch paper retaining clips (2).
- 4) Open panel to chassis latch (3) RH side plate.
- 5) Slide drive belts. (9) from chamfered grooves to center of top roller to release pressure on paper.
- 6) Remove supply roll (4). If paper is still attached to supply roll, carefully slide the paper from between the front panel and chart drive. Do not pull the paper backwards through the recorder because of the danger of snagging the pointer.
- 7) Insert the supply roller into the new roll of chart paper. The perforated end of the paper is nearest to the roller shoulder.
- 8) Unroll about a foot of paper. Slide the paper between the panel and side plate, sprocket holes first. Keep paper taut and close to the drive drum to prevent snagging the pointer.
- 9) Engage the supply roller shaft in both seating notches (6) and check to be sure that the paper sprocket holes engage the time drum sprockets.
- 10) Pull drive belts (9) back into the grooves (10).
- 11) Close clips (2), latch (3), and recorder front panel. Tighten thumbscrew(1).
- 12) Advance paper with the chart advance wheel (8), to assure that paper drives through the recorder. Set to time.

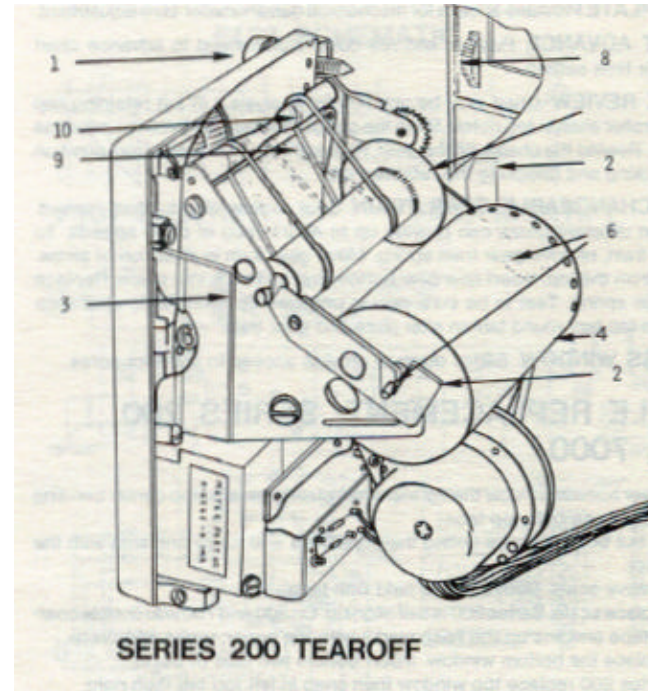

RECORDER STANDARD FEATURES, SERIES 200, 300, 4000, 7000

REROLL OR TEAROFF Chart drive mode may be quickly changed. Follow the instructions printed on the back of the nameplate.

NAMEPLATE Provides access for mechanical galvanometer zero adjustment.

CHART ADVANCE Push in and roll down thumbwheel to advance chart paper for time setting.

QUICK REVIEW Chart may be unrolled for analysis. Lift left retaining clip and set roller shaft in top notch. Snap the clip back in place. Unroll the paper as needed. Rewind the chart with the gear. Return the shaft to the bottom position by unlocking and relocking the retaining clip.

INTERCHANGEABLE GEAR TRAIN Gear trains affect chart speed. Fourteen different gears can provide up to 480/1 ratio of chart speeds. To change train, remove gear train spring. Move gear train in direction of arrow. Lift out from the top. Insert new gear bottom first and slide into place. Replace gear train spring. Test to be sure gear is engaged by noting zero clearance between top half round tab on side plate and gear train.

ACCESS WINDOW Slides down to provide access to chart for notes.

SCALE REPLACEMENT, SERIES 200, 300, 7000

- 1) Lower access window then grasp white plastic bezel at top center bending it to release both top tabs.
- 2) Lift out both windows noting their positions and lay to one side with the bezel.
- 3) Remove scale. Series 300 is held with tape.
- 4) Replace scale. Series 200 is self aligning. On 300 and 700 add double coated tape and line up the hash marks with the paper; press into place.
- 5) Replace the bottom window. Insert bottom two tabs of bezel.
- 6a) Series 200 replace top window then snap in left top tab then right.
- 6b) Series 300 and 7000 replace bezel as in 6a) then replace top window by putting it in one side then bending window so that it slides in on the other side.
- 7) Check access window to be sure of proper operation.

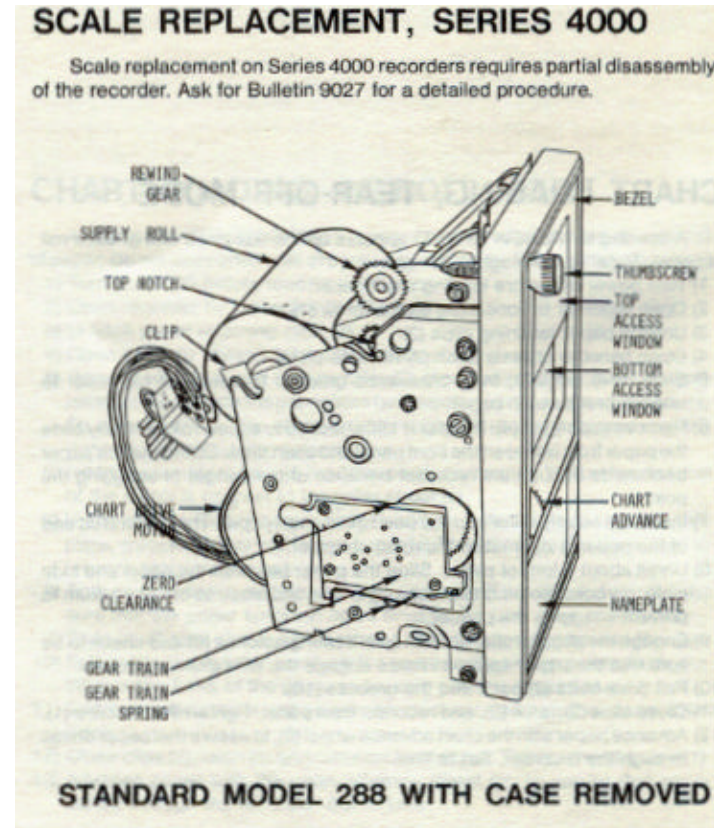

TWO POINT FEATURE OPERATION, (F137)

Series 200, 300, 4000 or 7000 may be equipped with two point feature in any or all channels.

A SPDT microswitch is activated by a cam with half the number of lobes as the striker cam. The microswitch activates a 4PDT relay which alternately connects the two channels to the galvanometer or if equipped with an amplifier feature to the amplifier input.

To identify channel 2 another cam geared to the time drum disconnects channel 2 every 1/4 inch of paper travel. See sample trace at right.

The signal sequence for each revolution of the chart drive motor is 1, 1, 2, 1, 2, 1, 2, 1, 2, 1, 2, 1, 2, 1, 2.

Some special DC powered recorders omit the 4PDT relay to conserve power. Both signals must have a common negative in this application.

FOUR POINT FEATURE OPERATION, (F437)

Series 7000 single channel, 100mm may be equipped with four point feature.

Refer to schematic at right. A leaf switch is actuated by the striker arm. The momentary closure triggers timer(15) which generates a 1.4 to 1.6 second pulse. This pulse is applied to the CLK1 input of JK flipflop(20). The two outputs from Q1 and Q2 provide the necessary coding to drive the multiplexer (19) whose four outputs are used to actuate DPDT relays used for signal switching.

Identification of the four recordings is accomplished by disconnecting each channel once each revolution of the time drum. This period is about 1/16" every 2.75 inches of paper. During the period that a channel is disconnected, a 1/16" trace is recorded. (See sample traces at right). The sampling sequence is channel 1, 2, 3, 4, 1, etc.

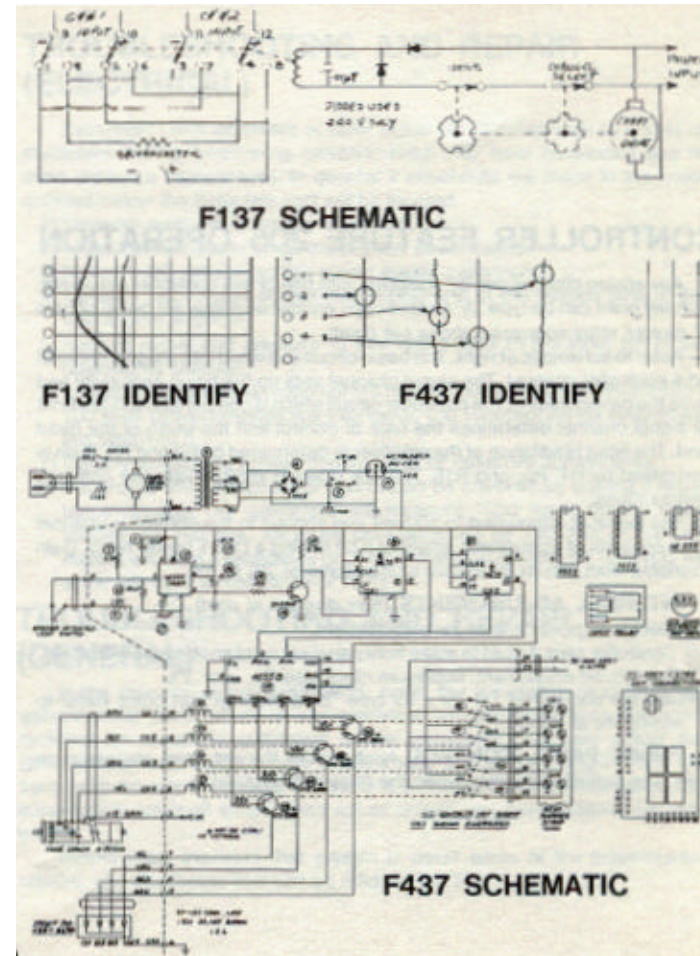

CONTROLLER FEATURE 205 OPERATION

Any analog channel can be equipped with one or two controller set points. Each set point can be type "A" (output relay energized below set point) or type "B" (output relay energized above set point).

Refer to schematic at right. The basic circuit is divided into a signal channel and a controller channel. The signal channel sets up the basic sensitivity and drives the galvanometer. The controller circuit which is completely isolated from the signal channel determines the type of control and the width of the dead band. The input resistance of the amplifier is determined by R2 and R3. Gain is determined by R4, R5, and R16. Rustrak drawing B-5919 lists the common configurations.

The signal is attenuated to 100 mV and applied to the controller channel which consists of operational amplifier (Q2) driving a DPDT power relay. Gain is variable from 500 to 20 to give a dead band of 2% to 5%.

INTERNAL ADJUSTMENTS (See diagram at right).

R9 Electrical galvanometer zero adjustment.

R10 Controller zero. Adjust to make front panel set point knob agree with scale.

R11 Dead band adjustment. Maximum clockwise 5%, ccw .2%.

Jumpers are configured | | or x for type "B" or type "A" set point. Refer to schematic at right..

FRONT PANEL CONTROL Knob moves the set point any place on scale. The panel lamp glows when the relay is energized.

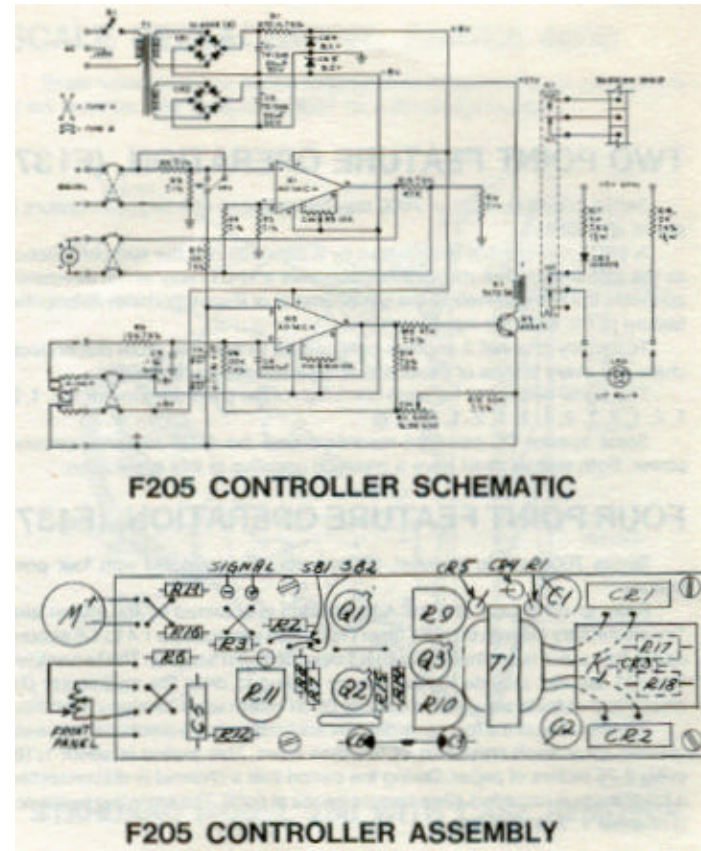

TROUBLESHOOTING AND REPAIR (MECHANICAL)

Before returning an instrument to the factory or service center for repair, check the items mentioned in this section. Recorders returned to the factory for repair are subject to a minimum charge whether or not they are defective. All instruments returned to the factory are routinely recalibrated. If you know the problem or symptom be sure to include the information with the instrument. Be familiar with how the recorder operates. Refer to sections in this manual that pertain to the portion of the recorder that is malfunctioning.

If the recorder does not operate at all, check to see if instrument is properly connected to the correct power source as indicated on the serial plate. Be sure power switches, if any, are in the "on" position.

Following is a description of some common problems and possible solutions.

GALVANOMETER DOESN'T FOLLOW THE SIGNAL

With striker in its maximum open position the distance between the striker and paper should be 1/8". The pointer should be midway. If the pointer is not centered, the galvanometer could have a bent pointer, broken taut band, cracked jewel. Defects not so visible such as open or shorted coil or debris in the air gap will cause the problem.

CHART SPEED FAST OR SLOW

All AC powered recorders use synchronous motors to drive the chart so a properly functioning recorder will not have timing errors. Recorders with unregulated motors can be expected to gain or lose several hours a day in the worst case. Recorders with inverter motors will keep time to within seven minutes a day. If chart speed is fast, the brake spring may be too weak or the clutch too tight. This is sometimes indicated by tears through the lower side of the sprocket holes. If chart speed is slow, the brake spring may be too tight or the clutch too loose. Slow chart can also be caused by a very soft or spongy roll of chart paper sometimes indicated by tears through the top side of the sprocket holes. Other causes of slow chart speed are such things as gear train slipping out of engagement because of a

weak gear spring. An intermittent or low torque chart motor will cause slow speed.

TROUBLESHOOTING AND REPAIR (ELECTRICAL)

Instruments with amplifiers or other signal conditioning such as shunts or multipliers having functioning galvanometers may have developed one or more defective components. In general if checkouts are made in the order outlined below the defective part will be located.

- 1) Measure main power on the PC board.
- 2) Measure AC voltage on all transformer secondaries.
- 3) Measure DC voltage across power supply capacitors.
- 4) Measure DC voltage across each zener and at the voltage pins of the operational amplifier.
- 5) Apply a signal and measure to see that it gets to the input pin of the operational amplifier.
- 6) All amplifier type signal conditioners have an output of 100 millivolts into a 100 ohm load. Galvanometers are 1 milliamp, 100 ohm except series 7000 which are 5mA 140 ohm.
- 7) Visually inspect for broken connections, or defective components.
- 8) Recorders with multipliers or shunts can be checked by making a resistance reading. DC voltmeters will measure 1000 times the full scale voltage. (ie 100 VDC full scale resistance will be 100,000) DC current meters will have a resistance of .1 + full scale DC current. (ie 10 mADC full scale will have a resistance of 10 ohm)

TROUBLESHOOTING AND REPAIR (GENERAL)

In the process of troubleshooting, resist the temptation to change the galvanometer zero adjust or any electrical adjustments unless you have facilities for complete calibration of the instrument. You may adjust the galvanometer zero but first note where it was, and after moving it return the zero (with no signal applied) to where it belongs. If the galvanometer has suppression (zero off scale) don't adjust unless you have facilities for calibration.

SERIES 200, 300, 4000 REPLACEABLE PARTS

A-4553-P1	Tearoff Drive Belt (2 Reqd.)
A-3280	Chart Advance Thumbwheel
A-4218-P1	Thumbwheel Screw
A-4219-G1	Thumbwheel Hinge Bracket
A-4422-P1	Thumbscrew (Panel)
A-4557-P1	Thumbscrew Retaining Ring
specify Pt. No.	Gear Train
A-2354	Gear Train Spring
A-4478-G1	Chart Review Arm & Gear
A-5151-P1	Retaining Clip For Supply Roll
A-4185-P2	Brake Spring
A-2313-P2	Brake
Note 1	Galvanometer
C-4214-P2	Chassis Latch
A-4551 -P1	Pin For Chassis Latch (2 Reqd.)
A-4252-P1	Chart Advance Ratchet
A-4251-P1	Chart Advance Ratchet Stiffner
Note 1	Chart Drive Motor & Cam
L-473-5	Parts Price List
L-479	Exploded View Model 288

SERIES 200 REPLACEMENT PARTS

B-4488-G1	Take Up Roller
B-2316-P1	Supply Roller
B-4550-G1	Time Drum
A-2254-P	Cardboard Spool Striker & Arm
B-4117-P1	Top Front Panel Bezel Bottom Front Panel Bezel (Nameplate)

NOTE 1:When ordering replacement galvanometers or chart drive motors specify the part number on the part.

SERIES 200 REPLACEABLE PARTS (continued)

B-41178-P1	Top Window
B-4179-P1	Bottom Window
A-4558-P1	6 Pin Female Cable Connector
L-479	Exploded View Model 288
L-473-5	Parts Price List
Note 1	Chart Drive Motor and Cam

SERIES 300 REPLACEMENT PARTS

B-4953-G1	Take Up Roller
B-4768-P1	Supply Roller
B-4766-G1	Time Drum
A-2254-P	Cardboard Spool Striker & Arm
C-6956	Top Front Panel Bezel Bottom Front Panel Bezel (Nameplate)
B-4776-P1	Top Window
B-4777-P1	Bottom Window
MSS-22	Power Slide Switch
Note 1	Chart Drive Motor & Cam
L-473-5	Parts Price List

SERIES 4000 REPLACEABLE PARTS

B-5866-G2	Take Up Roller
B-5867-G2	Supply Roller Time Drum
A-2254-P8	Cardboard Spool Striker & Arm
B-5591-G2	Top Front Panel Bezel
B-5543-P2	Bottom Front Panel Bezel (Nameplate)
B-5557-P1	Top Window
B-5554-P1	Bottom Window 3 Station P.B. Switch
Note 1	2 Speed Chart Drive Motor & Cam

STANDARD CHART PAPER, 200 SERIES (SINGLE WIDTH)

MINOR DIVISIONS	MAJOR DIVISIONS	STYLE/PT
20	4	G
30	6	I
40	8	H
50	10	A
60	12	K
65	13	C
75	15	B
80	16	L
15	3(2 channel)	F
20	10(2 channel)	D

CHART PAPER FOR SPECIFIC MODELS, 200 SERIES

DESCRIPTION	MODEL USED ON	STYLE/PN
50 Div + 1 Event	2146	N
4 or 8 Events	292-4 or 8	EE
25, 100, 300 Amps AC	230	0
150, 300, 600 Volts AC	230	R
60 to 90F/10 to 90% RH	225	P
—20 to +80 F + Event	238	C-5873

STANDARD CHART PAPER, 300 SERIES (DOUBLE WIDTH)

LEFT CHANNEL	RIGHT CHANNEL	STYLE/PT #
G	G	WGG
I	I	WII
A	A	WAA
N	N	WNN
D	D	WDD
D	EE	WDEE
A	EE	WAEE
EE	EE	W16E
A	P	C-6804
A	D	WAD
A	I	WAI

STANDARD CHART PAPER, 4000 SERIES (TRIPLE WIDTH)

LEFT	MIDDLE	RIGHT	STYLE/PT*
A	A	A	AAA
EE	EE	EE	24E
D	D	D	DDD
N	N	N	NNN
A	A	EE	AAE
D	D	EE	DDE

STANDARD CHART PAPER, 7000 SERIES

ANALOG DIV	EVENTS	STYLE/PT #
50	3	A-100mm