

## Stroboscope Model DT-314

## Instruction Manual

### Operational Precautions

- Do not operate or store in the following places:
  - Explosive areas.
  - Near water, oil, dust or chemicals.
  - Areas where temperature is above 104°F (40°C).
- Do not look at the emitted light for long periods of time; it can be harmful to the eyes.
- Do not disassemble or repair unit.
- Use tripod screw  $\frac{1}{4}$  - 20unc, length 8mm or shorter, for the tripod screw hole on the bottom.

### Dimensions

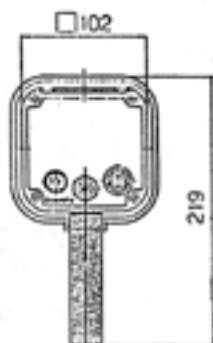
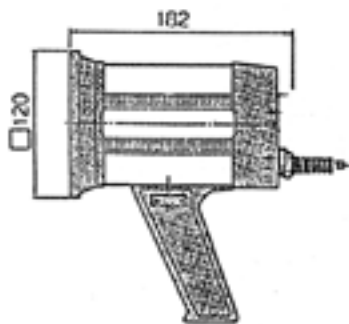

### Designations

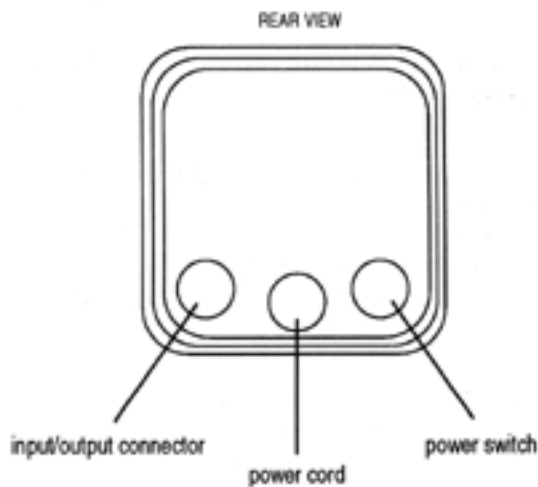

### Input/Output Connections

Connect signal wires with main body of the instrument after soldering the wires to connectors.

### Connector Pin Designation

1. +12V (power for sensor)
2. Synch output signal (optional)
3. External input signal
4. OV (common)

### Input Signal

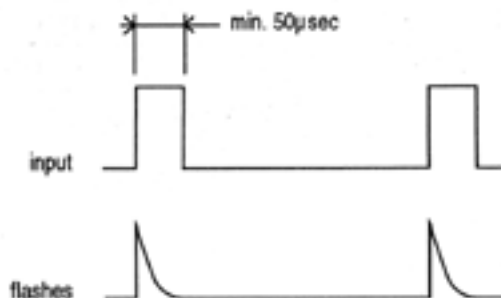

## Output Signal (Optional)

The output is synchronized to the input.

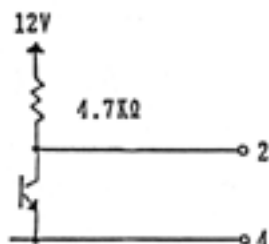

## Operation

1. Plug power cord into AC115V (optional AC230V) single phase.
2. Turn power switch on.
3. Aim strobe at object under observation. The best distance between the strobe and moving object is approximately 2 ft.

## Specifications

Flashing range	0 - 15,000 FPM
Input signal	Pulse width 50µs min. 1. LO level: 0 - 0.4VDC, HI level: 2.5 - 12VDC 2. Open collector (npn)
Impedance	10K
Flashtube	Xenon, 10W maximum
Flash duration	Approx. 50 microseconds
Sensor power supply	12VDC ± 0.5V (50ma)
Power requirements*	115VAC or 220VAC ± 10% 60/50Hz, 30VA
Operating temperature	32 - 104°F (0 - 40°C)
Dimensions (WxHxL)	4.72" x 4.72" x 7.19" (120 x 120 x 182.5)mm
Weight	2.4 lbs (1.1 kg)

\*Specify voltage

## Flash Tube Replacement

If unit is not flashing, tube may have to be replaced.

1. Unplug line cord from power line. Wait a few minutes until stroboscope is cool before replacing tube.
2. Remove the lamp protective window by removing the 4 screws.
3. Remove reflector from unit.
4. Insert tube-removing tool (provided) and turn clockwise until tool locks. Pull out tube.
5. Install new flash lamp using removing tool.
6. Re-attach reflector and protective window.

