



## LONG-RANGER Timer

The ATC 365C is the latest generation in the popular long-ranger timer series. The microprocessor-based digital timer is equipped with three rotary knobs for setting and adjustment of the Preset. The Preset can be any three-digit value from .01 SEC to 999 HR. The Decimal and Range are switch selectable. The high-intensity blue vacuum fluorescent display is DIP switch selectable to Timeup or Timedown. Two heavy-duty 7A DPDT relays provide instantaneous, interval or delayed output control. Plug-in panel mounting allows easy replacement without the removal of field wiring.

**COMPUTATION:** Through its internal microcomputer, the 365B keeps track of the set point throughout the time cycle. Whenever there is a change in set point, even during a cycle, it instantly re-computes the time remaining and accurately determines time-out. This unique capability is especially valuable in the time-down modes as it allows you to shorten a cycle without loss of accuracy.

**POSITIVE RESET TIME AND PULSE LENGTH:** Digitally clocked by the micro-computer, the 365C's reset time is consistently of the same duration, regardless of variations in line voltage, power supply or time cycle. As a result, the 365C is not subject to false reset from momentary power interruptions (less than 30 mSEC). When the 365C operates in repeat-cycle mode, the output pulse is also digitally clocked so that both its occurrence and duration are consistent.

**WIDE RANGE:** Each 365C Long-Ranger covers the overall span of 0.01 SEC to 999 HR, in nine switch-selected ranges of 0 to 9.99, 99.9 or 999 SEC, MIN or HR. The timer can be optimized within any selected range simply by removing appropriate selector knobs (e.g. with the timer in the 9.99 SEC range, you can obtain a tamper-proof span of 0.99 by setting the left selector at 0 and removing the knob).

**PROGRAMMABLE DISPLAY:** Depending on the position of an internal jumper, the 365C's three-digit cycle progress display will time UP to or DOWN from the set point; after time-out, it will either STOP or GO (i.e. display the time elapsed after time-out). To the right of the three-digit display, a timing bar "■" blinks once per second during the timing cycle and rapidly after time-out. At left, a marker "▼" turns on when the delayed relay is energized. The 365C is also available without display but with a pilot light that blinks once per second during the cycle and rapidly after time-out.

**NOISE IMMUNITY:** The 365C has formidable defenses against noise: transformer power supply, full-wave bridges, buffered logic. Furthermore its microcomputer detects; and rejects; noise pulses that manage to penetrate its defenses. No industrial timer has ever offered greater noise immunity.

**RELIABILITY AND RUGGEDNESS:** ATC firmly believes that no industrial timer has ever achieved a higher level of reliability and ruggedness. The 365C's electronic components have no moving parts and are assembled, virtually without hand wiring, from computer-tested circuit boards. Its few mechanical components have been selected for reliable service; the two load relays have a life expectancy of 100,000,000 operations and heavy-duty contacts rated at 7 amps; and the three rotary set point selector switches exhibit extremely low wear.

**COMPACT, PLUG-IN AND DUST-TIGHT:** Packaged in a 72mm<sup>2</sup> DIN housing, the 365C occupies 40% less panel space than conventional timers. It is a true plug-in timer that can be replaced in seconds without disturbing housing or wiring. The 365C is also fully gasketed and O-ring sealed to be dust and water-tight.

**SELF DIAGNOSTICS:** The time will display "FAIL" anytime there is a problem or the knobs are in between digits.

### DIMENSIONS (INCHES/MILLIMETERS)

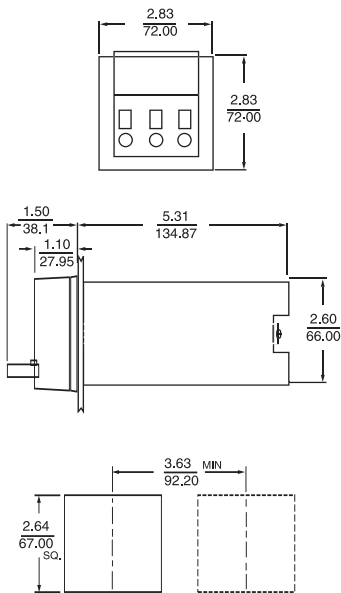

PANEL CUTOUT  
SHOWING DISTANCE BETWEEN  
ADJACENT CUTOUTS.

## SPECIFICATIONS

MODELS	Arrangement "30," with digital display available for On-Delay operation at 120, 240 or 24 VAC; and 24, 48 or 125 VDC	
RANGES	Switch-selectable ranges of 0-9.99, 0-99.9 and 0-999 SEC, MIN or HR	
TIMING MODES	Single Cycle	interval or delayed.
	Repeat Cycle	pulse-clocked at 50 to 80 mSEC (will be constant for a given unit)
RESET TIME	Clocked at 60 mSEC	
DISPLAY CYCLE PROGRESS	3 digit display, 0.3 inch, high-intensity, blue programmable: DOWN and STOP, DOWN and GO, UP and STOP or UP and GO	
	TIME-OUT	▼ display (left); energized at time-out.
TIMING BAR	display (right); blinks once per second during cycle, rapidly after time-out.	
CLOCK INPUT (terminal 15) VOLTAGE MODEL	120VAC Model	95-132VAC, 10mA max. current at 120V
	240VAC Model	190-264VAC, 10 mA max. current at 240V
	24VAC Model	19.2-26.4VAC, 20 mA max. current at 24V
	24VDC Model	19.2-26.4VDC (5% ripple), 5 mA max. current at 24V
	125 VDC Model	19.2 to 26.4 VDC 50mA DC Max.
125 VDC	100 to 150 VDC 15mA DC	
TEMPERATURE RATING	32 to 140°F (0 to 60°C)	

POWER REQUIREMENTS	120 VAC	95-132 VAC, 50 or 60 Hz. Inrush — .3A. Running 0.06A at 120 VAC	
	240 VAC	90-264 VAC, 50 or 60 Hz. Inrush — .15A. Running — 0.03A at 240 VAC	
	24 VAC	19.2-26.4 VAC, 50 or 60 Hz Inrush — 1A. Running — 0.25A at 24 VAC	
	24 VDC	19.2-26.4 VDC, 5% ripple Running — .120A AT 24 VDC	
LOAD RELAY	Number	one instantaneous and one delayed	
	Type	DPDT, Form C.	
	Operate Time	P 13 mSEC, max.	
	Release Time	10 mSEC, max.	
	Contact Ratings	7A at 120, 240 or 24 VAC 1/6 HP	
Life	100 million operations (no load)		
REPEAT ACCURACY	± .001% ±.010 SEC of setting		
SETTING ACCURACY	±.01% + .030 SEC of setting		
TERMINALS	16 screw terminals accessible at rear		
HOUSING	72mm <sup>2</sup> DIN size; plug-in design; fully gasketed, dust and water-tight in panel mounted installations.		
MOUNTING ACCESSORIES (See Accessory section of catalog)	Standard	<i>hardware is provided for front-of-panel mounting.</i>	
	Optional	<i>Surface-mounting brackets with front-facing terminals.</i>	
	NEMA 12 molded case (1 timer)		
WEIGHT	NET: AC 1 lb., 6 oz., DC 14 oz.	Shipping: AC 2 lbs. DC 1 lb., 8 oz.	

## WIRING

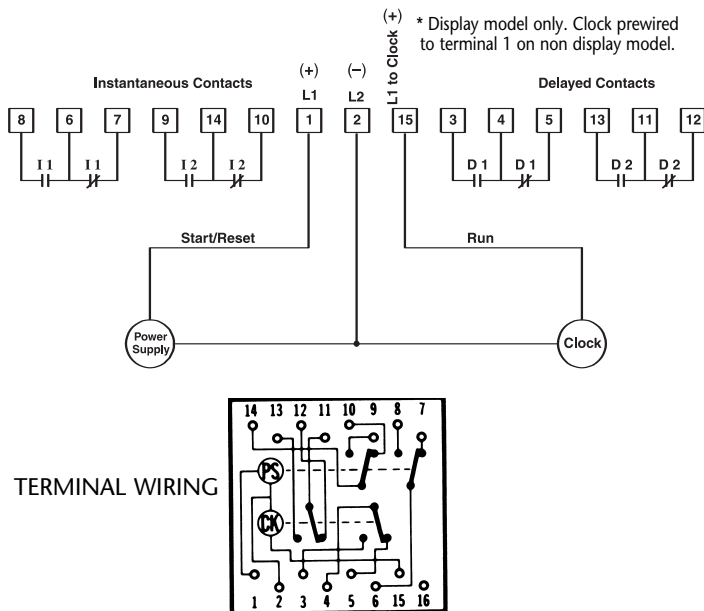

MODEL NUMBER >>>>>>	365C				P
Range	0 to 9.99, or 99.9 or 999 SEC, MIN, or HR	300			
Special	000				
Voltage & Frequency	125 VDC	L			
	24 VDC	N			
	120 VAC 50-60 Hz	Q			
	240 VAC, 50-60 Hz	R			
	24 VAC, 50-60 Hz	T			
Special	K				
Arrangement	With display, ON-delay/Time up or down and stop (reset on power failure)	30			
	Time up or down and go	50			
Features	Basic plug-in unit	p			
	Standard unit	X			
	Special	K			
ACCESSORIES	353-260-27-00: Surface Mounting Bracket Kit				
	305-265-61-70: Retrofit Kit				

THE 365C DIRECTLY REPLACES 365BA.

## OPERATION

As soon as power is applied to terminals 1 & 2 of the timer, the instantaneous relay is energized and changes the states of its associated contacts (8-6-7 & 9-14-10). The timer then looks for terminal 15 (the clock terminal) to receive power. When terminal 15 is powered, the internal clock circuit is enabled and the timer starts to time. When the internal clock time equals the time set on the front face, the delayed relay energizes and changes the states of its associated contacts (3-4-5 & 13-11-12). The timer is reset by removing power from terminal 1 for at least 60 msec. At reset, both relays revert back to their shelf (without power) state.

**SPECIAL NOTE FOR UNITS WITHOUT DISPLAYS:** On non-display units, terminals 1 & 15 are jumpered together internally. As soon as power is applied, the instantaneous relay energizes and the timer starts to time immediately.

**DISPLAY INFORMATION:** The digital display can be set to operate in any of 4 modes by simply moving a jumper on the circuit board.

MODE:

- UP & STOP (30PX Time up to time set, transfer delayed relay, and stop timing).
- UP & GO (50PX Time up to time set, transfer delayed relay, and continue timing until unit is reset).
- DOWN & STOP (30PX Time down to zero from time set, transfer delayed relay, and stop timing).
- DOWN & GO (50PX Time down to zero from time set, transfer delayed relay, and continue timing up from zero giving a direct overshoot reading. Timing will continue until unit is reset). All 365C timers are shipped from the factory in the UP & STOP mode.

## TYPICAL INSTALLATIONS

### KEY SYMBOLS

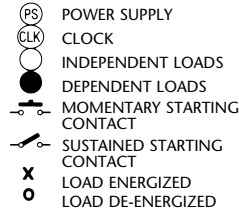

All timers shown in "before start" position. Diagrams shown with power off unless otherwise marked.

Maximum load current through any load carrying contact is 7 amperes.

ON DELAY Reset on power failure.

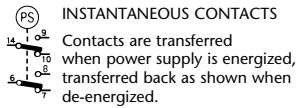
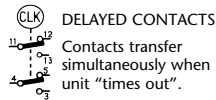

### SUSTAINED START

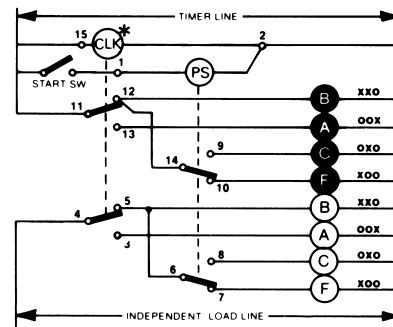

### MOMENTARY START

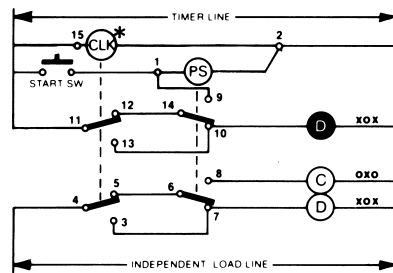

### REPEAT CYCLE PULSE

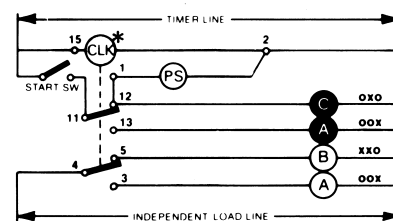

Load A pulses on for approximately 50 mSEC.

**ISE, Inc.**

10100 Royalton Rd.  
Cleveland, OH 44133

Tel: (440) 237-3200  
Fax: (440) 237-1744  
www.iseinc.com