



# Series 353

## SHAWNEE II Digital Programmable Timer

*A compact version of the versatile 333 Timer, the ATC 353 is its exact functional duplicate. Packaged in a 72mm<sup>2</sup> DIN-Size housing, it occupies 40% less panel space and costs proportionately less. Modern production and assembly techniques have all but eliminated hand wiring, enhancing the reliability and life expectancy of the 353.*



### The 353B Directly Replaces 353A.

## PRODUCT HIGHLIGHTS

### CONTROL VERSATILITY

The 353 operates either as a repeat cycle pulse generator or in single-cycle interval or delayed mode: you choose the kind of control action you want by installing jumpers on the terminal block. It also provides a choice of control output; a standard plug-in SPDT relay or optional SPST solid-state switch module plus an independent-24VDC output signal at Terminal 16.

### COMPUTER TESTED RELIABILITY

The solid-state 353 is manufactured from a series of computer-tested plug-in circuit boards and assembled virtually without hand wiring. Because it has no moving parts in its logic circuits, its life expectancy is practically unlimited. Even the load relay -- the 353's only significant mechanical component -- has a life expectancy of 100,000,000 operations (no load), while the optional solid-state switch module has virtually unlimited life expectancy. As a result, the 353 achieves an overall reliability that surpasses even the high level achieved by previous Shawnee timers.

### SAVE 40% IN PANEL SPACE AND COST

Packaged in a 72 mm<sup>2</sup> DIN-size housing, the 353 occupies 40% less panel space than previous IC timers. Modern production and assembly techniques have substantially reduced manufacturing costs and resulted in a 45% cost saving.

### WIDE RANGE

Each Shawnee II 353 timer covers the overall span of 0.01 sec to 999.9 min in four field-convertible ranges.

### EASY TO SET AT ALL TIMES

The Shawnee timer is easily and accurately set even with work gloves on. Push any of its four toggle levers in any sequence until the number you want appears above it. You can decrease as well as increase each number by pushing the levers *up* or *down*. You can change the setting at any time, even during a cycle.

### NOISE IMMUNITY

The 353 does not have to be shielded: its transformer power supply, full-wave bridges, buffered logic and other design characteristics render it immune to the electrical noise that is sometimes encountered in industrial environments thus eliminating false *starts* and *reset* due to voltage spikes.

### CYCLE PROGRESS INDICATION

The Shawnee 353 indicating timer provides cycle progress indication on a four-digit display located immediately above the digital setting number wheels. While the non-indicating Model 353 does not provide true cycle progress indication, it has a *pilot light* which is **on** during the timing cycle and a *legend light* which is **on** when there is power to the timer.

### OUTSTANDING REPEAT ACCURACY

Unsurpassed among industrial timers regardless of cost, the Shawnee 353 has a repeat accuracy of  $\pm 10$  milliseconds on any setting within its overall range of 999.9 min, even in the face of wide swings in temperature or voltage and regardless of the amount of reset time between cycles.

### PLUG-IN AND DUST-TIGHT

All 353 timers feature true plug-in design and are dust-tight from the front of panel.

### APPROVALS

See Agency Listing on inside back cover of catalog.

**OPERATION**

The Shawnee 353 operates on a digital logic circuit with three main elements: a *clock* which uses utility line frequency of 50 or 60 Hz as its time base; a *read-only-memory* (ROM) whose output is set by the timer's digital setting number wheels; and a *comparator* that continuously examines the outputs of the clock and ROM.

When power is applied (start signal **on**), the clock begins to count each cycle of the utility line frequency. Translating this count into hundredths of a second, the clock accumulates it and feeds it continuously to the comparator. When clock output exactly equals the output of the ROM, the 353 times out.

At that instant, the clock turns itself off automatically.

At the same instant, the 353 generates one type of control action or another, depending on how it is wired.

When the 353 is wired for interval operation, the timer's output device (either the standard SPDT relay or the optional SPST switch module) is energized from the start to the end of the time cycle; so is the -24V DC output at terminal 16.

When the 353 is wired for delayed control, the output device is energized at the end of the cycle and remains **on** until the timer is reset; so is the -24 V DC output. When the 353 is wired as a repeat cycle pulse generator, the output device and the DC signal are both **off** until the end of the cycle, at which time they are both **on** for about 80 ms. The length of the pulse is included in the time cycle: the cycle runs from the start of one pulse to the start of the next. The 353 automatically starts a new cycle immediately after reset.

The duration of the standard output pulse generated by the 353 is 80 ms(±20 ms), but it can be easily lengthened or shortened by using a capacitor or resistor across terminals 4 and 11.

To *shorten* the output pulse, the size of the resistor (fixed or variable) is calculated as follows:

$$\frac{2.2t - 2.64}{80-t} = R$$

Where: t = time in milliseconds (± 25%)  
 R = resistance in megohms  
 (must be at least 0.2 megohm.)

To *lengthen* the output pulse, the size of the capacitor is calculated as follows:

$$\frac{T - 0.08}{1.6} = C$$

Where: T = time in seconds (± 25%)  
 C = capacitance in microfarads.

**NOTE** --Observe Polarity:  
 + Terminal of the capacitor goes to 11  
 -- Terminal to 4

To *start* from AC voltage, jumper terminals 8-9 and 4-11 and start with AC power at terminals 1 and 2.

**TYPICAL INSTALLATION**

**DELAYED MODE — Sustained\* start**

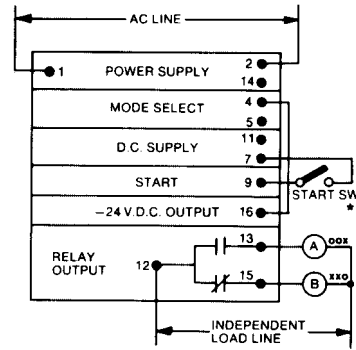

**INTERVAL MODE — Sustained\* or momentary\*\* start**

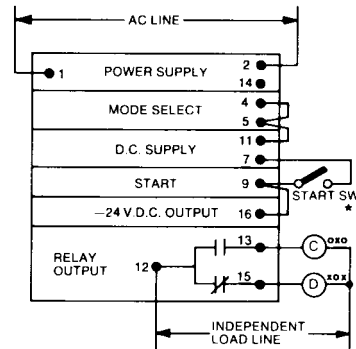

**INTERVAL MODE — Sustained\* start**

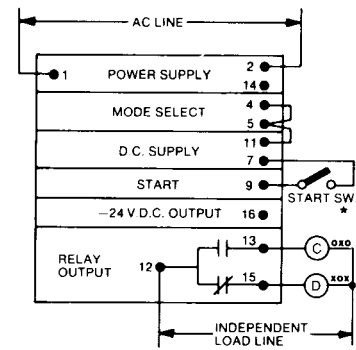

**REPEAT CYCLE PULSE GENERATOR —**

**Uninterrupted start signal**

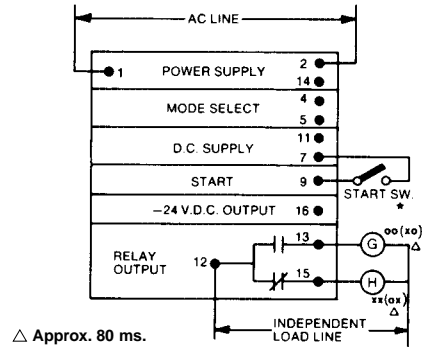

\*Start switch must be closed — or DC start signal must be **on** — for entire cycle. Timer resets when start switch opens or DC start signal turns **off**. to start from DC voltage, apply external ground on 11 and start signal on 9.

\*\*Start switch may be closed — or DC start signal may be **on** — for less that the entire cycle. Timer resets at end of cycle.

## SPECIFICATIONS

### MODELS

Both indicating and non-indicating models of the 353 are available. See ordering code.

### CYCLE PROGRESS INDICATOR (indicating model only)

4 digit, 0.3 inch, high intensity, blue display.

### RANGES

Four field convertible ranges:

- 0.01 - 99.99 sec,
- 0.01 - 99.99 min.
- 0.1 - 999.9 sec.
- 0.1 - 999.9 min.

### REPEAT ACCURACY

±0.01 sec. on all ranges.

### MINIMUM SETTING

99.99 sec or min ranges: 0.01 sec or min, respectively.

999.9 sec or min ranges: 0.1 sec or min, respectively.

### TIMING MODES

Single cycle (interval or delayed) and repeat cycle pulse generator.

### START/RESET SIGNAL

VOLTAGE REQUIREMENTS:

POSITIVE POLARITY: Ready at 4.5V min.

Reset at 1.0V

max.

NEGATIVE POLARITY: Ready at 3.0V min.

Reset at 1.0V

max

MAX. CONTINUOUS INPUT: 40V.  
RIPPLE VOLTAGE: must not go below minimum required.

AC LINE VOLTAGE  
INPUT IMPEDANCE: 5K ohms.

### RESET TIME

CIRCUIT RESET: 1 ms max.

RELAY DROP-OUT: 20 ms max.

### START SWITCH REQUIREMENTS (isolated contact)

SWITCH RATING: 10mA 30V

MIN. OPEN RESISTANCE: 1 megohm  
MAX. CLOSED RESISTANCE: 20K ohms

### LATCHING MODE OPERATION (interval only)

MIN. DURATION START SIGNAL: 50 us.

MAX. DURATION START SIGNAL: continuous.

RESET: when signal is removed.

### PULSE GENERATOR OPERATION

PULSE ON TIME(with relay): 80 ms. ± 20 ms (may be shortened or lengthened by installing a resistor or capacitor, respectively, across Terminals 4 and 11; see Operation Section for details.)

### LOAD RELAY

LIFE 100,000,000 operations (no load.)

CONTACT RATING: 5A at 120V AC  
2A at 240V A  
0.1A at 125V DC

### SOLID-STATE SWITCH MODULE (Optional)

Switches external DC voltage supply of positive polarity, 4 to 30V, 50 mA max. (details of operation described in installation manual.)

### DC OUTPUT (Terminal 16)

VOLTAGE: ON -- -24V ± 10%

OFF -- -1V or less

CURRENT: with relay -- 5 mA max.

without relay -- 40 mA max.

IMPEDANCE: on -- 10 ohms max.

off -- 10K ohms.

### DC POWER SUPPLY OUTPUT (Terminal 7)

VOLTAGE: -24V ± 10%

CURRENT: 40 mA max.

### POWER REQUIREMENTS

120V: 95 to 132V, 50/60 Hz

inrush -- 0.4 A

running -- 0.04 A

240V: 190 to 264V, 50/60 Hz

inrush -- 0.2 A

running -- 0.02 A

### TEMPERATURE RATING

0 to 60°C (32°F to 140°F.)

### WEIGHT

NET: 1 lb., 7 oz.

SHIPPING: 2 lbs.

### MOUNTING ACCESSORIES

STANDARD: Hardware is provided to mount timer so that it is dust-tight from front of panel.

OPTIONAL: Surface mounting without and with front-facing terminals. (See Accessory section of catalog)

NEMA 12 case (1 timer)

## DIMENSIONS:

INCHES  
MILLIMETERS

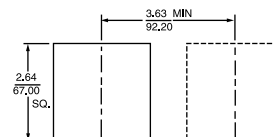
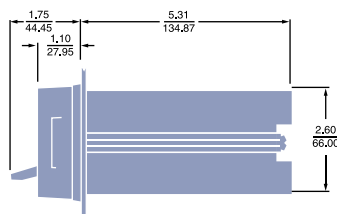
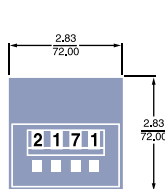

PANEL CUTOUT  
SHOWING DISTANCE BETWEEN  
ADJACENT CUTOUTS.

### TERMINAL WIRING

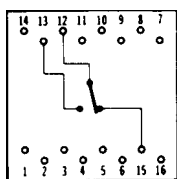

### TERMINAL WIRING

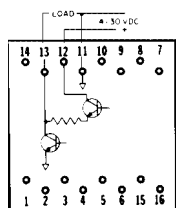

SOLID STATE  
OUTPUT MODULE

### WIRING

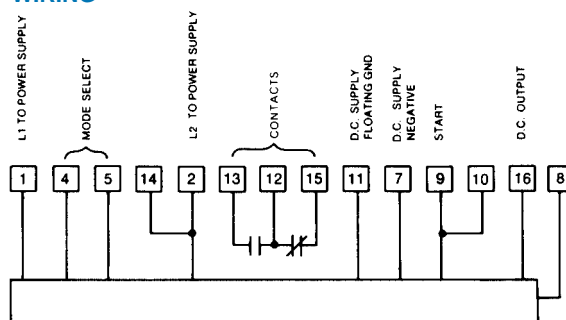

Pilot light only on unit without display.

Before starting your design, read the safety statement on the inside back cover of the ATC catalog.

## SERIES 353 COMPACT IC DIGITAL PROGRAMMABLE TIMER

### ORDERING CODE

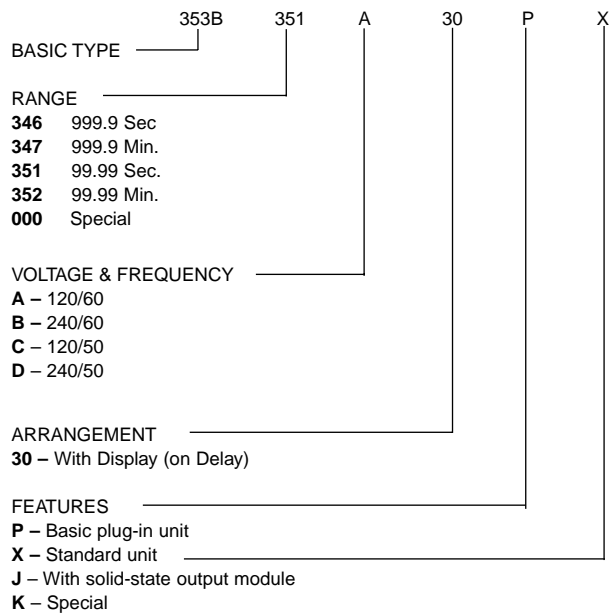

### ACCESSORIES

- 0353-260-27-00** Surface mounting bracket kit  
**0305-265-61-70** Retrofit kit

For prices and further information, consult factory

**The 353B Directly Replaces 353A.**